

LAPMASTER®

MODEL LLCD-SERIES

PRECISION OSCILLATING HEAD POLISHING MACHINE



- To complement our extensive range of Single and dual face lapping and polishing machines Lapmaster has introduced a new line of precision oscillating head polishing machines.
- Designated the LLCD series they are, primarily, Microprocessor controlled pad polishing machines specially designed for processing large area glass substrates, they can however also be used as lapping machines.
- A self aligning swing arm assembly positioned above the polishing surface is mounted to a swivel head work piece pressure plate. Work pieces of varying geometries can be retained by surface tension or vacuum to the pressure plate.
- The pressure plate is designed to swivel up from the horizontal working position to just past vertical to facilitate work piece loading and unloading.

- The LLCD series is also offered in a dual faced configuration, processing both sides at once via an oscillating carrier between two rotating plates.
- The machine consists of a heavy-duty base which houses both the polishing plate and the swing arm drive systems.
- The Polishing plate has a polishing pad (type dependent on material to be processed) bonded directly to its upper surface.
- Polishing compound is supplied to the centre of the Top or Bottom or both polishing plates via a re-circulatory pumped system. Water can also be supplied to the same destination on demand.
- The work piece pressure plate, which is positioned above the polishing plate, is attached to the swing arm via a selfaligning bearing.
- Both the stroke and radius of the swing arm are adjustable. This unique combination of rotating plate and oscillating work piece movement ensures:
 - Maximum utilization of the polishing surface.
 - Suppression and elimination of "tracking" effects on the polishing surface.
 - Improved control of polishing surface flatness.
 - Precise optical flatness control of work piece.
- The LLCD series of machines ability to be set up for use as a lapping or polishing means they can be used for processing large Plano optics including:

Calcium Fluoride	Fused Silica	BK7	Quartz	Zerodur
------------------	--------------	-----	--------	---------
- In addition to processing a wide variety of materials in an extensive range of industries:

L.C.D. Faceplates	SiliconWafers	I.C.	Photo masks	Crystalline substrates
(Sapphire, Gadolinium, Gallium Garnet etc.)			Ceramics	Ferrites
				Filter Glasses.



LLCD-SERIES STANDARD FEATURES

- Heavy duty steel base
- Variable speed range.
- Soft start to prevent work piece damage.
- Precision slurry distribution system and agitator
- Standard 380/415 volts, 50Hz, 3Ph electrics with 110v operator controls. Machines to suite other supplies available.
- Adjustable stroke and radius
- Auto cycle controlled by variable timer.
- All controls fully interlocked.

○ AVAILABLE OPTIONS

- Drives to bottom plate and swing arm independent via inverters.
- Fully enclosed guarding system.
- Independant drive to top and bottom plates.
- Double sided polishing.

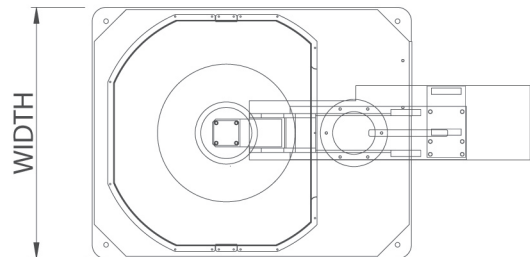
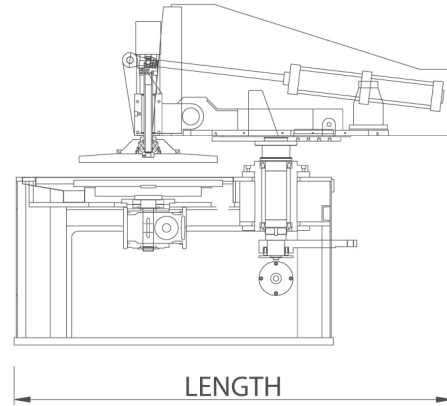
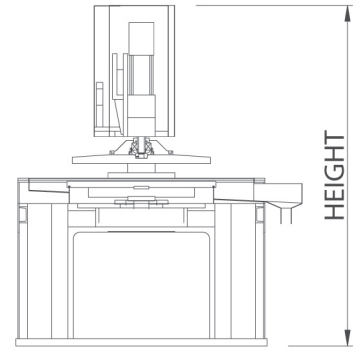

SPECIFICATIONS

	LLCD-600	LLCD-700	LLCD-800	LLCD-900	LLCD1000
DIAMETER OF LAPPING PLATE	600mm	700mm	800mm	900mm	1000mm
MAXIMUM DIAMETER OF WORKPIECES	480mm	580mm	680mm	730mm	780mm
DIAMETER OF PRESSURE PLATE	800mm	750mm	700mm	600mm	500mm
OSCILLATION STROKE	0-320mm	0-320mm.	0-320mm	0-320mm	0-320mm
MAIN MOTOR KW	2.2	2.2	3.7	3.7	5.5
LAPPING PLATE SPEED RPM	25-100	25-100	25-100	25-70	25-70
SWING ARM SPEED RPM	6.25-25 oscill./min	6.25-25 oscill./min	6.25-25 oscill./min	6.25-25 oscill./min	6.25-25 oscill./min
HEIGHT X LENGTH X WIDTH	1700 x 1700 x 1400	1753 x 1753 x 1397	1830 x 1880 x 1600	1956 x 2083 x 1702	2108 x 2210 x 1829
NET WEIGHT KG	1600	1800	2200	2550	2800

Lapmaster International 6400 West Oakton Street Morton Grove, IL 60053 U.S.A.
tel. 847.967.2975 fax 847.967.3903 toll free 877.352.8637 www.lapmaster.com

Lapmaster has a policy of continued development and the specifications outlined above are subject to change without notice.