



WAFER EDGE GRINDING SYSTEMS

- *Automated Cassette to Cassette Transfer Systems*
- *For both Semiconductor (soft) and Compound Semiconductor (hard) materials*
- *Wafer thickness measuring station*
- *Wafer centering and OF/Notch alignment features*
- *Systems available to process 2" to 12" diameters*
- *Programmable CNC controls for ease of operation, repeatable quality and fast diameter changes*
- *Menu-driven operations software utilizes Windows XP*
- *Optional post-grinding wafer cleaning and drying station*
- *4, 10 or 20 cassette to cassette systems available*
- *Automated interface to edge profile metrology available*
- *Ethernet network link interface capability*



Model #4101 CNC-Controlled 4-Cassette System

LAPMASTER

Wafer Edge-Grinding and Profiling System

EQUIPMENT SPECIFICATIONS

Centering accuracy:	+/- 0.030mm
Flat alignment accuracy:	+/- 0.03 degrees
Flat width accuracy:	+/- 0.500mm
Flat linearity:	Less than 0.010mm
Bevel width accuracy:	+/- 0.030mm
Main spindle run-out:	< 0.003mm (taper) < 0.005mm (radial *) < 0.005mm (axial *)
Wafer table run-out:	< 0.015mm (axial)

* (measured on host adapter)

UTILITY REQUIREMENTS

Electrical:	230V, 3P, 50/60Hz. 1.5 KVA
Compressed Air:	5Kg/cm2, 85NL/minute (max)
Coolant:	2kg/cm2, 2.5 liters/minute
Rinse Water:	2Kg/cm2, 2.0 liters/minute

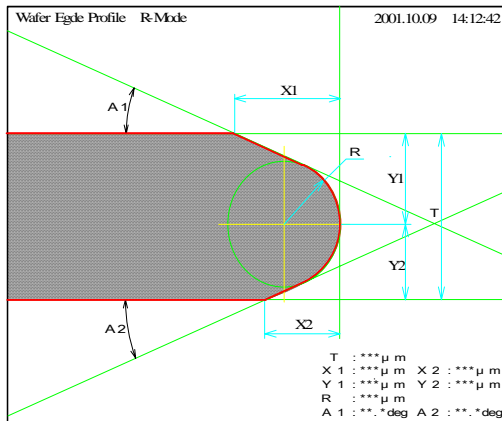

Metrology Interface Profile Evaluation Screen

SYSTEM FEATURES

- Reduced wafer diameter change-over time
- Most standard transfer cassette types accepted
- Works with both notched or OF edges
- Vacuum chuck transfer by horizontal X-Y robot
- Centering & OF/Notch adjustment on grinding table
- Positioning/centering does not require additional time
- Space efficient direct cassette to cassette transfer
- CNC system features override for manual runs
- Optional edge profile -OF/Notch metrology interface
- 2"-4", 3"-6" or 8"-12" wafer diameter systems
- Accessible mechanical design for easy maintenance
- Excellent operator access and ergonomics
- Affordable and compact production systems



View of CNC Controlled 10 Cassette to Cassette System



6400 West Oakton Street
Morton Grove, IL 60053 USA
Phone: (847) 967-2975
Fax: (847) 967-3903
Toll Free: 1-877-352-8637
Web Site: www.lapmaster.com